

SPECIFICATIONS

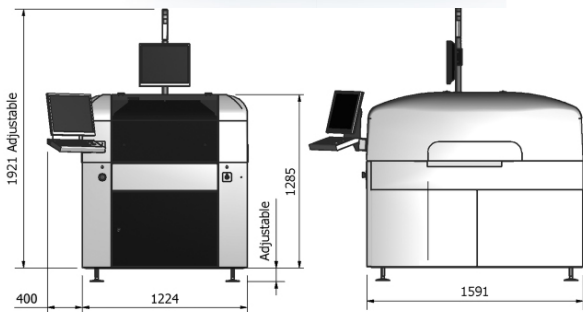

GENERAL	
Max board size	610mm (x) x 515mm (y)
Min board size	45mm (x) x 45mm (y)
Maximum PCB weight	1Kg (2.2lb)
Underside component clearance	15mm **30mm
Underside edge clearance	5mm
Minimum board edge clearance	3mm
Machine alignment repeatability	12.5µm @ 6 sigma 2Cpk
Full process repeatability	20µm @ 6 sigma 2Cpk
Max print area	600mm (x) x 510mm (y)
Max PCB thickness	Up to 8mm (0.2") including 1% warpage
Min PCB thickness	0.2mm
X/Y PCB alignment	± 5mm
Stencil image	Front and centre dedicated
Stencil load/unload	Automatic using print head (standard)
Stencil frame size (max)	736.6mm (29") x 736.6mm (29") max frame height 40mm
Stencil frame size (min)	584mm (23") x 584mm (23") max frame height 40mm
Squeegee material	Metal or polyurethane
Squeegee pressure	1-20Kg
Squeegee control	Pneumatic using proportional valve
Print speed	5-250mm/sec
PCB separation speed	0.1-20mm/sec
Print modes	Print/print, flood/print, print/flood
Transfer height	939.8mm (37") – 965.2mm (38")
Transfer height (Siemens)	830mm
Transport direction	Right-left, left-right, left-left, right-right
Transfer system	Single pair conveyors with round 3mm poly belt drive
Board clamping	Foils (standard) **Snugger
Board stop	Mounted on camera and fully programmable
Throughput time	11.5 seconds, optional 8 and 6 seconds (excluding print time)
Up/down line protocol	SMEMA (alternative interfaces available)
Conveyor orientation	Front rail dedicated
Conveyor width adjustment	Automatic (standard)
Conveyors	3mm "0" Ring
Internal machine lighting	LED internal machine lighting (standard)
SPI closed loop	Communication with all SPI machine that have a feedback system
Stencil paste roll inspections	Automatic measurement / alert (standard)
PCB support	Manual magnetic pins, **Laser tooling : position indicated by laser dot
Camera field of view	10mm by 10mm
Camera system	Dual roving camera, Look down/look down
Number of fiducials	2
Fiducial size	0.5 – 5mm
User interface	Flat screen LCD monitor with keyboard and integral tracker ball
Operating system	Microsoft Windows™ 7 or higher
Power consumption	13 Amps
Power supply	110V – 240V
Air supply	6 bar clean air supply
Air consumption	1.4 litres per cycle without clean, 16 litres during USC
Operating temperature	10°C to 35°C (50°F to 95°F), humidity 30% to 50% relative humidity (non condensing)
Weight	650Kg
Crated weight	800Kg

* Full movement of all axes incl. squeegee ** Optional

OPTIONS	
23" – 29" stencil capability	Red-E-Set™
2D paste inspection	Custom tooling
2D+ paste inspection with Gerber import tool and bridge detection	Stencil paste dispenser
Statistical Process Control (SPC)	Temperature Control Unit
Vacuum board support	Velocity
Laser guided tooling	Velocity+
Snugger PCB edge clamp	ADu, PCB glue & dispenser (710 ONLY)
Vacunest™	ADu+, PCB glue & dispenser (710 ONLY)
Quik-Tool™	Verification

As part of our policy of continuous development, specifications are subject to change without prior notice.